

Gasoline Pump

HYDRAULIC PG30/55 SERIES

30-55 cu. in./min.
Gasoline driven

Gasoline power supply ideal for remote locations. PG30 series for to 75 ton cylinders. PG55 series for up to 150 ton cylinders.

PUMPS

- A logical choice at work sites where electricity or compressed air are unavailable. For single- or double-acting cylinders at operating pressures to 10,000 psi.
- All gasoline engine/hydraulic pumps feature "Posi-Check" valve to guard against pressure loss when valve is shifted from "advance" to "hold".



PG303

PG303 and PG304

- Powered by a 2-cycle, 2 hp Tecumseh engine giving it the lowest weight to horsepower ratio of all gasoline driven pumps. Has an aluminum reservoir with 375 cu. in. of usable oil.
- Has same basic pump as PE30 series electric operated pumps.
- PG30 series pumps are equipped with roll cages to protect pump from damage.
- PG30 series pumps weigh in at only 32 lbs. with oil.
- PG303 is for single-acting cylinders, has a 9520 valve with separate internal return line; allows oil from running pump to return to reservoir, independently of cylinder return oil, when valve is in "return" position.
- PG304 is for double-acting cylinders, has a 9506 4-way (tandem center) valve.

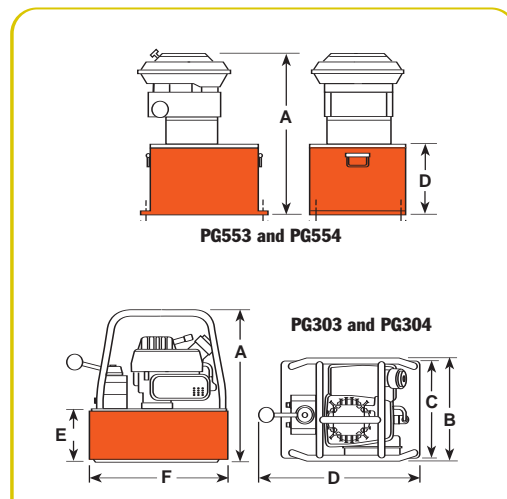
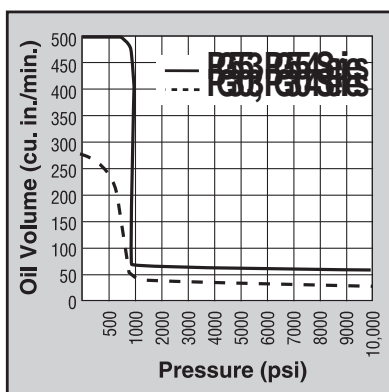

| Pump No. | Max. Pressure Output (psi) | rpm | Oil Del. (cu. in./min. @) | | | | A (in.) | B (in.) | C (in.) | D (in.) | E (in.) | F (in.) | Prod. Wt. w/Oil (lbs.) |
|--------------|----------------------------|-------|---------------------------|-------------|-------------|--------------|--------------------------------|--------------------------------|--------------------------------|-------------------------------|--------------------------------|--------------------------------|------------------------|
| | | | 100 (psi) | 1,000 (psi) | 5,000 (psi) | 10,000 (psi) | | | | | | | |
| PG303, PG304 | 10,000 | 6,000 | 275* | 40 | 35 | 30 | 14 ⁷ / ₈ | 10 ³ / ₈ | 9 ¹ / ₂ | 16 | 5 ¹ / ₈ | 13 ¹ / ₂ | 32 |
| PG553, PG554 | 10,000 | 3,600 | 480 | 75 | 70 | 55 | 22 | 18 | 12 ¹ / ₂ | 8 ⁵ / ₈ | 16 ⁵ / ₈ | 9 | 120 |

* First stage oil delivery from 0-400 psi @ 230 cu. in. per minute minimum.

PG554



10,000 psi

PG553 and PG554

- 6 hp Intek “Diamond Edge” 4-cycle, by Briggs & Stratton. 5 gallon reservoir.
- Same basic pump as PE55 series electrical Vanguard® pumps.
- PG553 has a 9520 3-way valve for single-acting cylinders.
- PG554 has a 9506 4-way valve for double-acting cylinders.

Gasoline Powered Hydraulic Pumps like this PG303 help provide hydraulic force at remote locations.



| For use with Cyl. Type | Description | Order No. | Valve Type | Valve No. | Valve Function | Reservoir Usable (cu. in.) | Horsepower | Cycle |
|------------------------|--|--------------|------------|-----------|---------------------|----------------------------|------------|-------|
| Single-Acting | 2 hp pump with 2 gal. reservoir and single-acting valve. | PG303 | 3-Way | 9520 | Advance Hold Return | 375 | 2 | 2 |
| Single-Acting | 6 hp pump with 5.7 gal. reservoir and single-acting valve. | PG553 | 3-Way | 9520 | Advance Hold Return | 1,300** | 6 | 4 |
| Double-Acting | PG303, except has double-acting valve. | PG304 | 4-Way | 9506 | Advance Hold Return | 375 | 2 | 2 |
| Double-Acting | PG553, except has double-acting valve. | PG554 | 4-Way | 9506 | Advance Hold Return | 1,300** | 6 | 4 |

** Usable oil is calculated with oil fill at recommended level at 1/2" below cover plate

