

The CRC.1 aluminium body allows the in-line mounting connections for CVS.20 sequence and CVR.20 pressure reducing valves. For pressure reducing version the body is provided with a one-way check valve, which allows free flow to opposite direction (P_R toward P). For the sequence version a blind grub screw has been placed instead of a check valve.

- Mounting the blind grub screw, code **M78100013**, it is possible to transform the body from reducing valve to sequence valve.
- Mounting the blind grub screw, code **V70052204**, it is possible to transform the body from sequence valve to reducing valve.

ORDERING CODE

CRC

Body for sequence and pressure reducing cartridge valve
Size 20 (seat M22x1,5)

1

Size connection 1/2" BSP

R = Pressure reducing cartridge valve
S = Sequence cartridge valve

Type of adjustment

M = Plastic knob

C = Grub screw

0 = Without cartridge valve

Setting ranges

1 = max. 60 bar (**white spring**)

2 = max. 120 bar (**yellow spring**)

3 = max. 250 bar (**green spring**)

0 = Without cartridge valve

00 = No variant

V1 = Viton

1

Serial No

HYDRAULIC SYMBOL

REDUCING VALVE VERSION

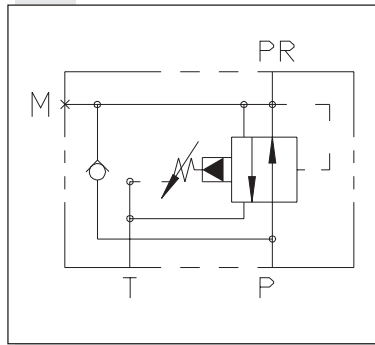

FREE FLOW TROUGH

THE CHECK VALVE

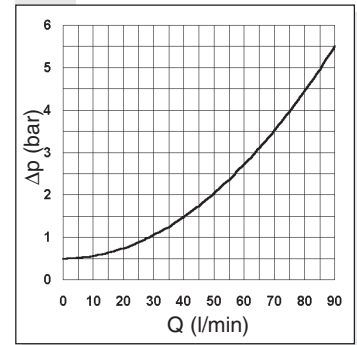

HYDRAULIC SYMBOL

SEQUENCE VALVE VERSION

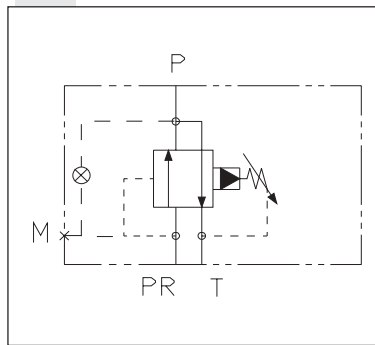

OVERALL DIMENSIONS

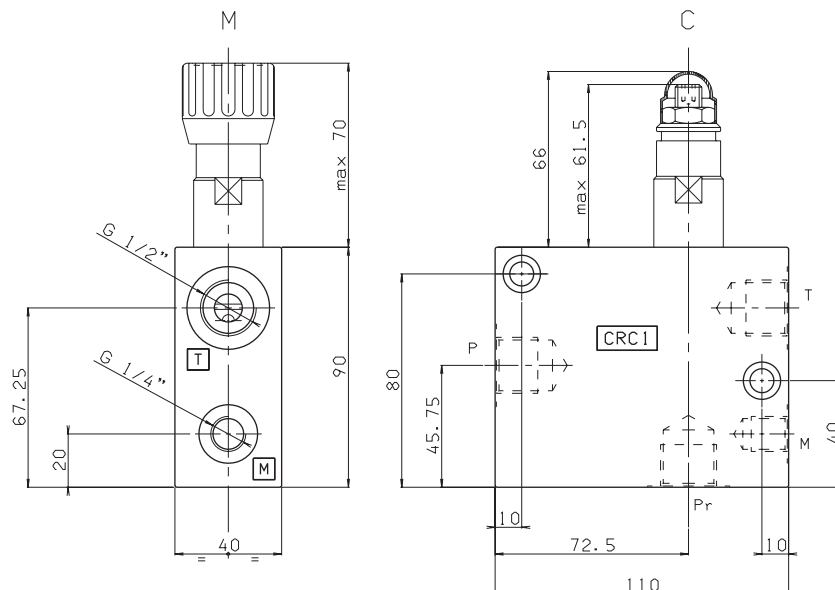

Type of adjustment

M Plastic knob

C Grub screw